

DETACHED GARAGES

ADDRESS _____

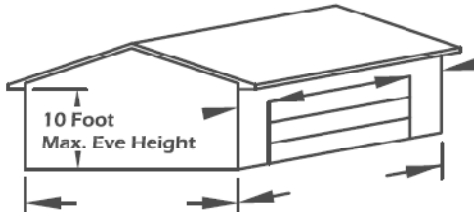

DOOR AT LOAD BEARING WALL

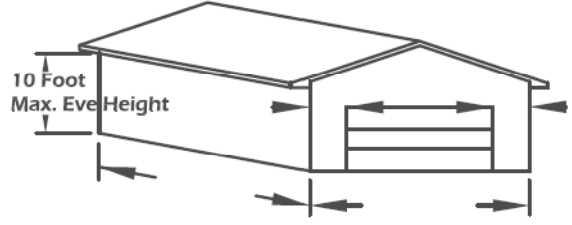

DOOR AT GABLE END

Enter Size of Garage _____ Enter Type of Footing _____

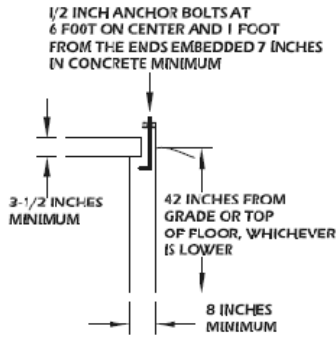

Trenched Footing

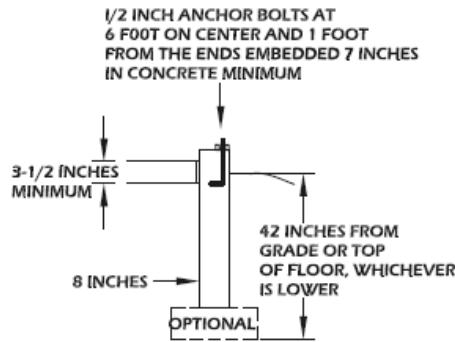

T- Footing

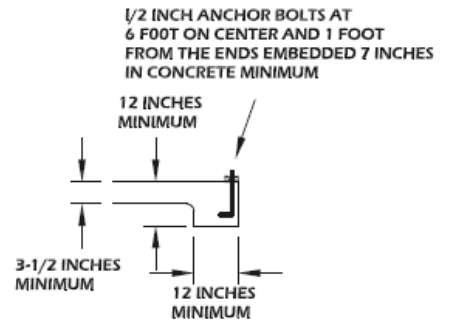

Slab on Grade

Type Exterior Wall Studs _____ Spacing _____ Headers _____
 Wall Sheathing _____ Siding _____
 Braced Wall Panels Size and Location _____
 Distance from Property Line Nth _____ Sth _____ Est _____ Wst _____
 Firewalls and Location _____ Overhang _____
 Pre-engineered Trusses _____ Rafters _____ Spacing _____
 Roof Sheathing _____ Roof Underlayment _____ Shingles _____

LOCATION ON LOT

Site plan. Prior to permit issuance, a site plan drawn to scale showing all proposed structures and setback dimensions on the lot, including corner pin elevations, minimum recommended ground elevation, and the lowest floor elevation for new dwellings, must be submitted to the Zoning Division for review and approval. It is the responsibility of the permit holder to maintain required landscaping and setbacks in accordance with the zoning ordinance.

Detached tool sheds and storage sheds, playhouses, and similar structures that are 200 square feet or less in area are exempted from building permits; however, will require a placement permit from the Zoning Division.

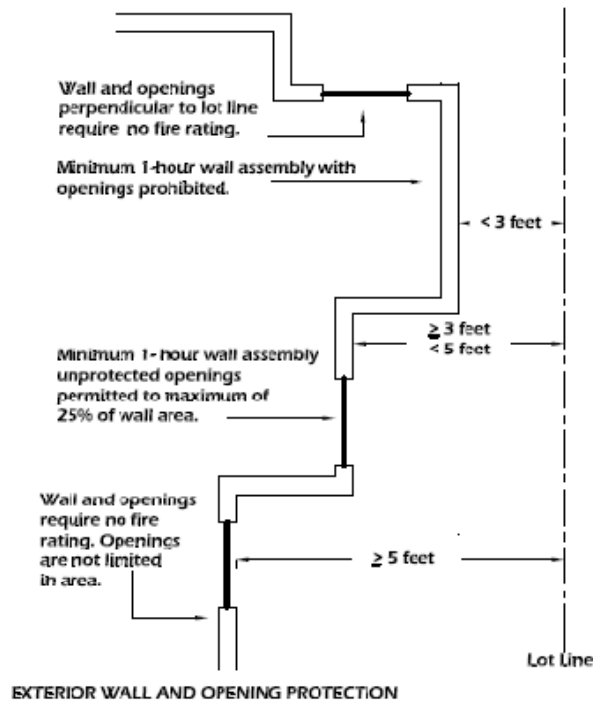

Exterior walls. Construction, projections, openings, and penetrations of exterior walls of dwellings and accessory buildings shall comply with the following table. These provisions shall not apply to walls, projections, openings, or penetrations in walls that are perpendicular to the line used to determine the fire separation distance. Projections beyond the exterior wall shall not extend more than 12 inches into the areas where openings are prohibited.

Exceptions.

1. Detached tool sheds and storage sheds, playhouses, and similar structures that are 200 square feet or less in area are exempted from building permits and are not required to be provided with wall protections based on location on lot. Projections beyond the exterior wall shall not extend over the lot line.
2. Detached garages accessory to a dwelling located within 2 feet of a lot line are permitted to have roof eave projections not exceeding 4 inches.

Exterior Wall Element		Minimum Fire-Resistance Rating	Minimum Fire Separation Distance
Walls	(Fire-resistance rated)	1 hour with exposure from both sides	0 feet
	(Not fire-resistance rated)	0 hours	5 feet
Projections	(Fire-resistance rated)	1 hour on the underside	≤ 3 feet
	(Not fire-resistance rated)	0 hours	≥ 3 feet
Openings	Not allowed	N/A	< 3 feet
	25% Maximum of Wall Area	0 hours	3 feet
	Unlimited	0 hours	5 feet
Penetrations	All	Protected	< 5 feet
		None required	5 feet

Separation required. The garage located less than 6 feet from the residence shall be separated from the residence by not less than 1/2–inch gypsum board applied to the garage side. Openings in these walls shall be as specified above. This provision does not apply to garage walls that are perpendicular to the adjacent dwelling unit wall.

Floor surface. Garage floor surfaces shall be of approved noncombustible material. The area of floor used for parking of automobiles or other vehicles shall be sloped to facilitate the movement of liquids to a drain or toward the main vehicle entry doorway.

Footings. Footings shall extend below the frost line, which is a minimum of 42 inches below finished grade. One-story wood or metal framed buildings not over 1,500 square feet, an eave height of 10 feet or less and not used for human occupancy, a detached garage, or storage shed, may have a floating slab foundation, a nonfrost foundation.

Anchor bolts. Anchor bolts shall be 6 foot on center and 1 foot from the ends of the bottom plate. Anchor bolts shall be a minimum of 1/2 inch in diameter and shall extend into the concrete a minimum of 7 inches.

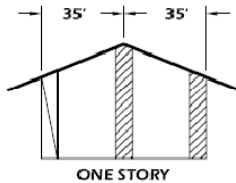

WALL BRACING

Due to the basic wind speed in Sioux Falls, defined as a 90-mph wind velocity, exterior walls and main cross partitions are required to be braced to resist wind forces.

Braced wall lines. Braced wall lines shall consist of braced wall panel construction in accordance with the following braced wall options. Braced wall panels shall begin no more than 12 feet 6 inches from each end of a braced wall line.

Braced wall panels that are counted as part of a braced wall line shall be in line, except that offsets out-of-plane of up to 4 feet shall be permitted provided that the total out-to-out offset dimension in any braced wall line is not more than 8 feet.

Exception: The offsets out-of-plane may exceed 4 feet and the out-to-out offset dimension may exceed 8 feet if the area of the offset is less than 200 square feet.

Spacing. Spacing of braced wall lines shall not exceed 35 feet on-center in both the longitudinal and transverse directions in each story.

Type A: Wall panel construction methods. The construction of braced wall panels shall be in accordance with one of the following methods:

- Nominal 1-inch by 4-inch continuous diagonal braces let in to the top and bottom plates and the intervening studs or approved metal strap devices installed in accordance with the manufacturer's specifications. The let-in bracing shall be placed at an angle not more than 60 degrees or less than 45 degrees from the horizontal.
- Wood boards of 5/8-inch net minimum thickness applied diagonally on studs spaced a maximum of 24 inches diagonally placed wood board braced wall panel shall be at least 48 inches in length, covering a minimum of three stud spaces where studs are spaced 16 inches on center and covering a minimum of two stud spaces where studs are spaced 24 inches on center.
- Wood structural panel sheathing with a thickness not less than 5/16 inch for 16-inch stud spacing and not less than 3/8 inch for 24-inch stud spacing. A wood structural panel braced wall panel shall be at least 48 inches in length, covering a minimum of three stud spaces where studs are spaced 16 inches on center and covering a minimum of two stud spaces where studs are spaced 24 inches on center.

- 1/2-inch- or 25/32-inch-thick structural fiberboard sheathing applied vertically or horizontally on studs spaced a maximum of 16 inches on center. A fiberboard sheathing braced wall panel shall be at least 48 inches in length, covering a minimum of three stud spaces where studs are spaced 16 inches on center and covering a minimum of two stud spaces where studs are spaced 24 inches on center.
- Gypsum board with minimum 1/2-inch thickness placed on studs spaced a maximum of 24 inches on center. A gypsum board braced wall panel shall be at least 96 inches in length where applied to one face of a braced wall panel and at least 48 inches where applied to both faces.
- Particleboard wall sheathing panels shall be at least 48 inches in length, covering a minimum of three stud spaces where studs are spaced 16 inches on center and covering a minimum of two stud spaces where studs are spaced 24 inches on center.
- Hard board panel siding braced wall panel shall be at least 48 inches in length, covering a minimum of three stud spaces where studs are spaced 16 inches on center and covering a minimum of two stud spaces where studs are spaced 24 inches on center.

Type B: Alternate braced wall panels. Alternate braced wall lines constructed in accordance with one of the following provisions shall be permitted to replace each 4 feet of braced wall panel referenced above.

- In one-story buildings, each panel shall be sheathed on one face with 3/8-inch-minimum thickness wood structural panel sheathing nailed with 8d common or galvanized box nails and blocked at all wood structural panel sheathing edges. Two anchor bolts shall be provided in each panel. Anchor bolts shall be placed at panel quarter points. Each panel end stud shall have a tie-down device fastened to the foundation, capable of providing an uplift capacity of 1,800 pounds. The tie-down device shall be installed in accordance with the manufacturer's recommendations. The panels shall be supported directly on a foundation or on floor framing supported directly on a foundation which is continuous across the entire length of the braced wall line.

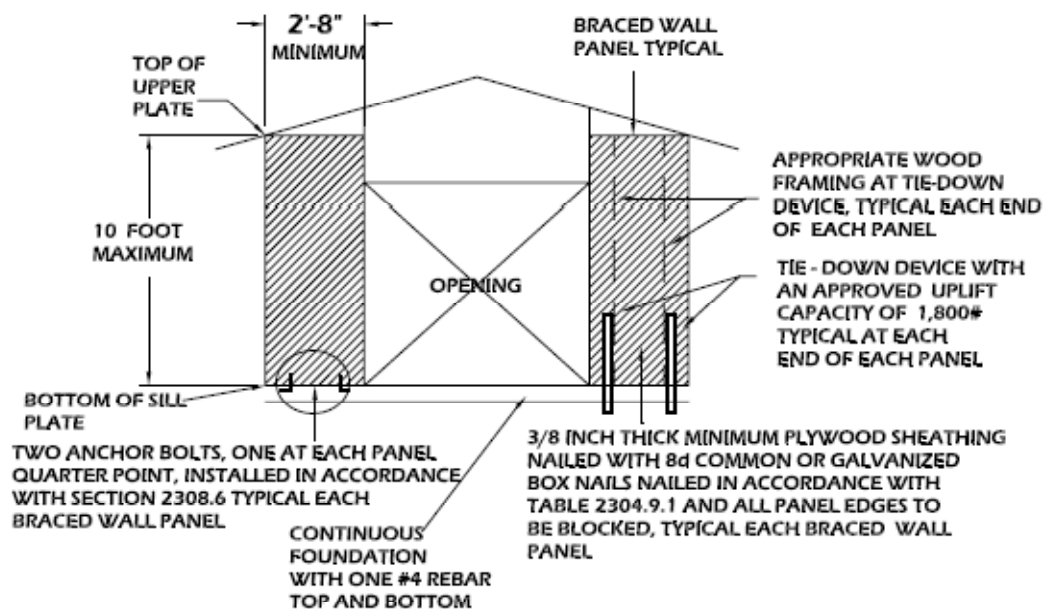

SCHEMATIC - ONE-STORY BUILDING ALTERNATE BRACED WALL PANEL

Type C: HBA Alternate braced wall panels. The minimum length of an alternate braced wall panel may be further reduced to 2 feet 0 inches if each panel is sheathed on both sides with a 3/8-inch-minimum thickness wood structural panel sheathing nailed in accordance with Table 11/R 602.3 and blocked at all wood structural panel edges. Two anchor bolts and tie-downs are required at each alternate braced panel.

Type D: Alternate braced wall panel adjacent to a door or window opening. Alternate braced wall panels constructed in accordance with one of the following provisions are also permitted to replace each 4 feet of braced wall panel as stated above for use adjacent to a window or door opening with a full-length header:

- In one-story buildings, each panel shall have a length of not less than 16 inches and a height of not more than 10 feet. Each panel shall be sheathed on one face with a single layer of 3/8-inch-minimum thickness wood structural panel sheathing nailed with 8d common or galvanized box nails. The wood structural panel sheathing shall extend up over the solid sawn or glued-laminated header. Use of a built-up header consisting of at least two 2 x 12s shall be permitted. A spacer, if used, shall be placed on the side of the built-up beam opposite the wood structural panel sheathing. The header shall extend between the inside faces of the first full-length outer studs of each panel. The clear span of the header between the inner studs of each panel shall be not less than 6 feet and not more than 18 feet in length. A strap with an uplift capacity of not less than 1,000 pounds shall fasten the header to the side of the inner studs opposite the sheathing. One anchor bolt not less than 5/8-inch diameter shall be installed in the center of each sill plate. The studs at each end of the panel shall have a tie-down device fastened to the foundation with an uplift capacity of not less than 4,200 pounds. Where a panel is located on one side of the opening, the header shall extend between the inside face of the first full-length stud of the panel and the bearing studs at the other end of the opening. A strap with an uplift capacity of not less than 1,000 pounds shall fasten the header to the bearing studs. The bearing studs shall also have a tie-down device fastened to the foundation with an uplift capacity of not less than 1,000 pounds. The tie-down devices shall be an embedded strap type, installed in accordance with the manufacturer's recommendations. The panels shall be supported directly on a foundation which is continuous across the entire length of the braced wall line.
- Each wall panel shall be braced in accordance above, except that each panel shall have a length of not less than 24 inches

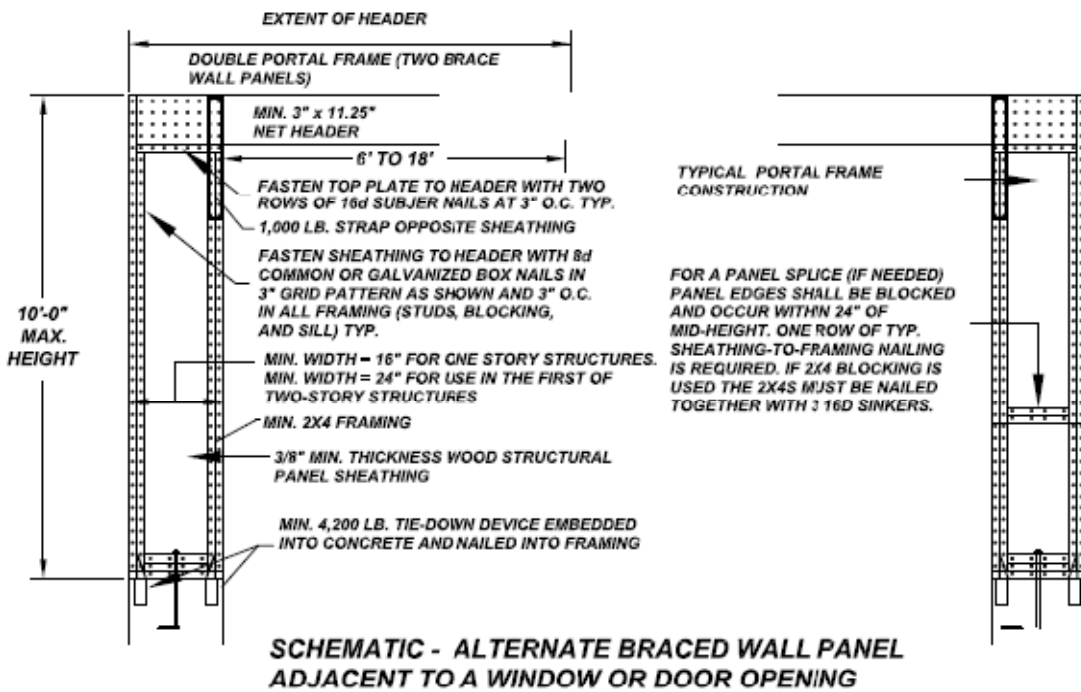

Panel joints. All vertical joints of panel sheathing shall occur over, and be fastened to, common studs. Horizontal joints in braced wall panels shall occur over, and be fastened to, common blocking of a minimum 1 1/2-inch thickness.

Connections. Braced wall line sole plates shall be fastened to top plates. Sills shall be fastened to the foundation or slab in accordance with above-referenced provisions. Where joists are perpendicular to the braced wall lines above, blocking shall be provided under and in line with the braced wall panels. Where joists are perpendicular to braced wall lines below, blocking shall be provided over and in line with the braced wall panels.

Exterior Covering

General. Exterior walls shall provide the building with a weather-resistant exterior wall envelope. The exterior wall envelope shall include flashing. The exterior wall envelope shall be designed and constructed in a manner that prevents the accumulation of water within the wall assembly by providing a water-resistant barrier behind the exterior veneer and a means of draining water that enters the assembly to the exterior.

Flashing. Approved corrosion-resistant flashing shall be applied shingle-fashion in such a manner to prevent entry of water into the wall cavity or penetration of water to the building structural framing components. The flashing shall extend to the surface of the exterior wall finish. Approved corrosion-resistant flashings shall be installed at all of the following locations:

- Exterior window and door openings. Flashing at exterior window and door openings shall extend to the surface of the exterior wall finish or to the water-resistive barrier for subsequent drainage.
- At the intersection of chimneys or other masonry construction with frame or stucco walls with projecting lips on both sides under stucco copings.
- Under and at the ends of masonry, wood, or metal copings and sills.
- Continuously above all projecting wood trim.
- Where exterior porches, decks, or stairs attach to a wall or floor assembly of wood frame construction at wall and roof intersections.
- At built-in gutters.

Attachments. Unless specified otherwise, all wall coverings shall be securely fastened in accordance as shown below or with other approved aluminum, stainless steel, zinc-coated, or other approved corrosion-resistant fasteners.

Weather-Resistant Siding Attachment and Minimum Thickness

SIDING MATERIAL		NOMINAL THICKNESS ¹ (inches)	JOINT TREATMENT	WATER-RESISTIVE BARRIER REQUIRED	TYPE OF SUPPORTS FOR THE SIDING MATERIAL AND FASTENERS ^{b, c, d}					Number or spacing of fasteners
					Wood or wood structural panel sheathing	Fiberboard sheathing into stud	Gypsum sheathing into stud	Foam plastic sheathing into stud	Direct to studs	
Horizontal aluminum ^a	Without insulation	0.019 ^f	Lap	Yes	0.120 nail 1½" long	0.120 nail 2" long	0.120 nail 2" long	0.120 nail ^g	Not allowed	Same as stud spacing
		0.024	Lap	Yes	0.120 nail 1½" long	0.120 nail 2" long	0.120 nail 2" long	0.120 nail ^g	Not allowed	
	With insulation	0.019	Lap	Yes	0.120 nail 1½" long	0.120 nail 2½" long	0.120 nail 2½" long	0.120 nail ^g	0.120 nail 1½" long	
Anchored veneer: brick, concrete, masonry or stone		2	Section R703	Yes	See Section R703 and Figure R703.7 ^h					
Adhered veneer: concrete, stone or masonry ^a		—	Section R703	Yes Note w	See Section R703.6.1 ^h or in accordance with the manufacturer's instructions.					
Hardboard ^d Panel siding-vertical		7/16	—	Yes	Note m	Note m	Note m	Note m	Note m	6" panel edges 12" inter. sup. ⁿ
Hardboard ^d Lap-siding-horizontal		7/16	Note p	Yes	Note o	Note o	Note o	Note o	Note o	Same as stud spacing 2 per bearing
Steel ^a		29 ga.	Lap	Yes	0.113 nail 1¾" Staple-1¾"	0.113 nail 2¾" Staple-2½"	0.113 nail 2½" Staple-2½"	0.113 nail ^v Staple ^v	Not allowed	Same as stud spacing
Particleboard panels		¾ - ½	—	Yes	6d box nail (2" x 0.099")	6d box nail (2" x 0.099")	6d box nail (2" x 0.099")	box nail ^v	6d box nail (2" x 0.099"), ¾ not allowed	6" panel edge, 12" inter. sup.
		5/8	—	Yes	6d box nail (2" x 0.099")	8d box nail (2½" x 0.113")	8d box nail (2½" x 0.113")	box nail ^v	6d box nail (2" x 0.099")	
Wood structural panel siding ¹ (exterior grade)		¾ - ½	Note p	Yes	0.099 nail-2"	0.113 nail-2½"	0.113 nail-2½"	0.113 nail ^v	0.099 nail-2"	6" panel edges, 12" inter. sup.
Wood structural panel lapsiding		¾ - ½	Note p Note x	Yes	0.099 nail-2"	0.113 nail-2½"	0.113 nail-2½"	0.113 nail ^v	0.099 nail-2"	8" along bottom edge
Vinyl siding ¹		0.035	Lap	Yes	0.120 nail (shank) with a 0.313 head or 16 gauge staple with 7/8 to 1/2-inch crown ^{2, z}	0.120 nail (shank) with a 0.313 head or 16 gage staple with 3/8 to 1/2-inch crown ²	0.120 nail (shank) with a 0.313 head or 16 gage staple with 3/8 to 1/2-inch crown ²	0.120 nail (shank) with a 0.313 head per Section R703.11.2	Not allowed	16 inches on center or specified by the manufacturer instructions or test report
Wood ^h rustic, drop		¾ Min	Lap	Yes	Fastener penetration into stud-1"			0.113 nail-2½" Staple-2"	Face nailing up to 6" widths, 1 nail per bearing; 8" widths and over, 2 nails per bearing	
Shiplap		7/32 Average	Lap	Yes						
Bevel		7/16	Lap	Yes						
Butt tip		3/16	Lap	Yes						
Fiber cement panel siding ³		5/16	Note q	Yes Note u	6d common corrosion-resistant nail ^f	6d common corrosion-resistant nail ^f	6d common corrosion-resistant nail ^f	6d common corrosion-resistant (12" x 0.113") nail ^{v, y}	4d common corrosion-resistant nail ^f	6" o.c. on edges, 12" o.c. on intermed. studs
Fiber cement lap siding ³		5/16	Note s	Yes Note u	6d common corrosion-resistant nail ^f	6d common corrosion-resistant nail ^f	6d common corrosion-resistant nail ^f	6d common corrosion-resistant (12" x 0.113") nail ^{v, y}	6d common corrosion-resistant nail or 11 gage roofing nail ^f	Note t

- Based on stud spacing of 16 inches on center where studs are spaced 24 inches, siding shall be applied to sheathing approved for that spacing.
- Nail is a general description and shall be T-head, modified round head, or round head with smooth or deformed shanks.
- Staples shall have a minimum crown width of 7/16-inch outside diameter and be manufactured of minimum 16 gage wire.
- Nails or staples shall be aluminum, galvanized, or rust-preventative coated and shall be driven into the studs for fiberboard or gypsum backing.

- e. Aluminum nails shall be used to attach aluminum siding.
- f. Aluminum (0.019 inch) shall be unbacked only when the maximum panel width is 10 inches and the maximum flat area is 8 inches. The tolerance for aluminum siding shall be +0.002 inch of the nominal dimension.
- g. All attachments shall be coated with a corrosion-resistant coating.
- h. Shall be of approved type.
- i. 3/8-inch plywood shall not be applied directly to studs spaced more than 16 inches on center when long dimension is parallel to studs. Plywood 1/2 inch or thinner shall not be applied directly to studs spaced more than 24 inches on center. The stud spacing shall not exceed the panel span rating provided by the manufacturer unless the panels are installed with the face grain perpendicular to the studs or over sheathing approved for that stud spacing.
- j. Wood board sidings applied vertically shall be nailed to horizontal nailing strips or blocking set 24 inches on center. Nails shall penetrate 1 1/2 inches into studs and wood sheathing combined or blocking.
- k. Hardboard siding shall comply with CPA/ANSI A135.6.
- l. Vinyl siding shall comply with ASTM D3679.
- m. Minimum shank diameter of 0.092 inch, minimum head diameter of 0.225 inch, and nail length must accommodate sheathing and penetrate framing 1 1/2 inches.
- n. When used to resist shear forces, the spacing must be 4 inches at panel edges and 8 inches on interior supports.
- o. Minimum shank diameter of 0.099 inch, minimum head diameter of 0.240 inch, and nail length must accommodate sheathing and penetrate framing 1 1/2 inches.
- p. Vertical end joints shall occur at studs and shall be covered with a joint cover or shall be caulked.
- q. See Section R703.10.1.
- r. Fasteners shall comply with the nominal dimensions in ASTM F1667.
- s. See Section R703.10.2.
- t. Face nailing: one 6d common nail through the overlapping planks at each stud. Concealed nailing: one 11 gage 1 1/2-inch-long galvanized roofing nail through the top edge of each plank at each stud.
- u. See Section R703.2 exceptions.
- v. Minimum nail length must accommodate sheathing and penetrate framing 1 1/2 inches.
- w. Adhered masonry veneer shall comply with the requirements of Section R703.6.3 and shall comply with the requirements in Sections 6.1 and 6.3 of ACI 530/ASCE 5/TMS-402.
- x. Vertical joints, if staggered, shall be permitted to be away from studs if applied over wood structural panel sheathing.
- y. Minimum fastener length must accommodate sheathing and penetrate framing .75 inches or in accordance with the manufacturer's installation instructions.

Horizontal siding. Horizontal lap siding shall be lapped a minimum of 1 inch, or 0.5 inch if rabbeted, and shall have the ends caulked, covered with a batten, or sealed and installed over a strip of flashing.

Window Header Schedule

Permissible Headers Lengths-Single-Story Trussed Roof Applications

Live Load = 28 psf Dead Load = 12 psf

367-8670	•	Building Services	•	City of Sioux Falls	•	2009 IRC
----------	---	-------------------	---	---------------------	---	----------

Member Size	Grade/Species	Roof Truss Span									
		18	20	22	24	26	28	30	32	34	36
2-2x8s	Hem Fir Select Structural	8'9"	8'4"	8'0"	7'9"	7'6"	7'3"	7'0"	6'10"	6'8"	6'6"
	Hem Fir #1 and Better	7'7"	7'3"	7'10"	6'9"	6'6"	6'3"	6'1"	5'11"	5'9"	5'7"
	Hem Fir #1	7'2"	6'11"	6'8"	6'4"	6'2"	6'0"	5'9"	5'8"	5'6"	5'4"
	Hem Fir #2	6'10"	6'6"	6'3"	6'0"	5'10"	5'8"	5'6"	5'4"	5'2"	5'0"
	Spruce Pine Fir Select Structural	8'3"	7'11"	7'7"	7'4"	7'1"	6'10"	6'8"	6'5"	6'3"	6'1"
	Spruce Pine Fir #1/#2	6'11"	6'7"	6'4"	6'1"	5'11"	5'9"	5'7"	5'5"	5'3"	5'1"
	Douglas Fir Larch Select Structural	8'11"	8'6"	8'2"	7'11"	7'7"	7'4"	7'2"	7'0"	6'9"	6'7"
	Douglas Fir Larch #1	7'5"	7'1"	6'10"	6'6"	6'4"	6'1"	5'11"	5'9"	5'8"	5'6"
	Douglas Fir Larch #2	6'11"	6'7"	6'4"	6'1"	5'11"	5'9"	5'7"	5'5"	5'3"	5'1"
2-2x10s	Hem Fir Select Structural	10'8"	10'3"	9'10"	9'6"	9'2"	8'10"	8'7"	8'4"	8'1"	7'11"
	Hem Fir #1 and Better	9'3"	8'10"	8'6"	8'2"	7'11"	7'8"	7'5"	7'3"	7'0"	6'10"
	Hem Fir #1	8'9"	8'5"	8'1"	7'10"	7'6"	7'4"	7'1"	6'10"	6'8"	6'6"
	Hem Fir #2	8'4"	8'0"	7'8"	7'3"	7'1"	6'11"	6'8"	6'6"	6'4"	6'2"
	Spruce Pine Fir Select Structural	10'1"	9'8"	9'3"	8'11"	8'8"	8'4"	8'1"	7'11"	7'8"	7'6"
	Spruce Pine Fir #1/#2	8'5"	8'1"	7'9"	7'6"	7'3"	7'0"	6'9"	6'7"	6'5"	6'3"
	Douglas Fir Larch Select Structural	10'8"	10'5"	10'0"	9'8"	9'4"	9'0"	8'9"	8'6"	8'3"	8'1"
	Douglas Fir Larch #1	9'0"	8'9"	8'4"	8'0"	7'9"	7'6"	7'3"	7'1"	6'10"	6'8"
	Douglas Fir Larch #2	8'5"	8'1"	7'9"	7'6"	7'3"	7'0"	6'9"	6'7"	6'5"	6'3"
2-2x12s	Hem Fir Select Structural	12'5"	11'10"	11'5"	11'0"	10'7"	10'3"	10'0"	9'8"	9'5"	9'2"
	Hem Fir #1 and Better	10'9"	10'4"	9'10"	9'6"	9'2"	8'11"	8'8"	8'5"	8'2"	8'0"
	Hem Fir #1	10'4"	9'9"	9'5"	9'1"	8'9"	8'5"	8'3"	8'0"	7'9"	7'7"
	Hem Fir #2	9'8"	9'3"	8'11"	8'7"	8'3"	8'0"	7'9"	7'6"	7'4"	7'2"
	Spruce Pine Fir Select Structural	11'9"	11'3"	10'9"	10'5"	10'0"	9'9"	9'5"	9'2"	8'11"	8'8"
	Spruce Pine Fir #1/#2	9'10"	9'4"	9'0"	8'8"	8'5"	8'1"	7'10"	7'8"	7'5"	7'3"
	Douglas Fir Larch Select Structural	12'7"	12'1"	11'7"	11'2"	10'9"	10'6"	10'2"	9'9"	9'7"	9'4"
	Douglas Fir Larch #1	10'6"	10'2"	9'8"	9'3"	9'0"	8'8"	8'5"	8'2"	8'0"	7'9"
	Douglas Fir Larch #2	9'10"	9'4"	9'0"	8'8"	8'5"	8'1"	7'10"	7'8"	7'6"	7'3"
3-2x8s	Hem Fir Select Structural	10'9"	10'3"	9'10"	9'6"	9'2"	8'11"	8'7"	8'3"	8'2"	7'11"
	Hem Fir #1 and Better	9'3"	8'11"	8'6"	8'3"	7'11"	7'8"	7'6"	7'3"	7'1"	6'10"
	Hem Fir #1	8'10"	8'6"	8'1"	7'10"	7'7"	7'4"	7'1"	6'11"	6'8"	6'6"
	Hem Fir #2	8'4"	8'0"	4'8"	7'5"	7'2"	6'11"	6'8"	6'8"	6'4"	6'2"
	Spruce Pine Fir Select Structural	10'2"	9'8"	9'4"	9'0"	8'8"	8'5"	8'2"	7'11"	7'8"	7'6"
	Spruce Pine Fir #1/#2	8'6"	8'1"	7'9"	7'6"	7'3"	7'0"	6'10"	6'7"	6'5"	6'3"
	Douglas Fir Larch Select Structural	10'11"	10'3"	10'0"	9'8"	9'4"	9'0"	8'9"	8'6"	8'4"	8'1"
	Douglas Fir Larch #1	9'1"	8'8"	8'4"	8'0"	7'9"	7'6"	7'4"	7'1"	6'11"	6'8"
	Douglas Fir Larch #2	8'6"	8'1"	7'9"	7'6"	7'3"	7'0"	6'10"	6'7"	6'5"	6'3"
3-2x10s	Hem Fir Select Structural	13'1"	12'6"	12'0"	11'7"	11'3"	10'10"	10'6"	10'3"	10'0"	9'9"
	Hem Fir #1 and Better	11'4"	10'10"	10'5"	10'0"	9'0"	9'5"	9'1"	8'10"	8'8"	8'5"
	Hem Fir #1	10'9"	10'4"	9'11"	9'7"	9'3"	8'11"	8'8"	8'5"	8'2"	8'0"
	Hem Fir #2	10'2"	9'9"	9'4"	9'0"	8'9"	8'6"	8'2"	8'0"	7'9"	7'7"
	Spruce Pine Fir Select Structural	12'3"	11'10"	11'4"	11'0"	10'7"	10'3"	9'11"	9'8"	9'5"	9'2"
	Spruce Pine Fir #1/#2	10'4"	9'11"	9'6"	9'2"	8'10"	8'7"	8'4"	8'1"	7'10"	7'8"
	Douglas Fir Larch Select Structural	13'4"	12'9"	12'3"	11'10"	11'5"	11'1"	10'9"	10'5"	10'2"	9'10"
	Douglas Fir Larch #1	11'1"	10'7"	10'2"	9'10"	9'6"	9'2"	8'11"	8'8"	8'5"	8'2"
	Douglas Fir Larch #2	10'4"	9'11"	9'6"	9'3"	8'10"	8'7"	8'4"	8'1"	7'10"	7'8"

3-2x12s	Hem Fir Select Structural	15'2"	15'7"	14'0"	13'7"	13'0"	12'7"	12'3"	11'10"	11'7"	11'3"
	Hem Fir #1 and Better	13'2"	12'7"	12'1"	11'8"	11'3"	10'11"	10'7"	10'3"	10'0"	9'9"
	Hem Fir #1	12'6"	12'0"	11'6"	11'1"	10'8"	10'4"	10'1"	9'9"	9'6"	9'3"
	Hem Fir #2	11'10"	11'4"	10'11"	10'6"	10'1"	9'10"	9'6"	9'3"	9'0"	8'9"
	Spruce Pine Fir Select Structural	14'4"	13'9"	13'2"	12'9"	12'3"	11'11"	11'6"	11'3"	10'11"	10'8"
	Spruce Pine Fir #1/#2	12'0"	11'6"	11'0"	10'8"	10'3"	9'11"	9'8"	9'4"	9'2"	8'11"
	Douglas Fir Larch Select Structural	15'6"	14'10"	14'9"	13'8"	13'3"	12'10"	12'5"	12'1"	11'9"	11'6"
	Douglas Fir Larch #1	12'10"	12'3"	11'10"	11'4"	11'0"	10'8"	10'4"	10'0"	9'9"	9'6"
	Douglas Fir Larch #2	12'0"	11'6"	11'0"	10'8"	10'3"	9'11"	9'8"	9'4"	9'2"	8'11"

Design Criteria: Based on a 28 psf live load due to snow on a roof having a slope greater than 3:12 and a 12 psf dead load. Roof loads include a 2' 0" overhang. Deflection is based on the span in inches divided by 240 for the total load. Stresses in bending are adjusted for a snow load duration factor of 15 percent and a size adjustment factor.

Overhead Garage Door Header Schedule

Live Load = 28 psf Dead Load = 12 psf

367-8670	• Building Services •	City of Sioux Falls	• 2009 IRC
----------	-----------------------------	---------------------	---------------

Number of Members Per Grade and Species/Solid Sawn Lumber for Single-Story Applications

9-Foot Spans											16-Foot Spans											
Roof Span	Header Size	Hem Fire Select Structural	Hem Fir #1 and Better	Hem Fir #1	Hem Fir #2	Spruce Pine Fir Select Structural	Spruce Pine Fir #1/#2	Douglas Fir Larch Select Structural	Douglas Fir Larch #1	Douglas Fir Larch #2	Roof Span	Header Size	Hem Fire Select Structural	Hem Fir #1 and Better	Hem Fir #1	Hem Fir #2	Spruce Pine Fir Select Structural	Spruce Pine Fir #1/#2	Douglas Fir Larch Select Structural	Douglas Fir Larch #1	Douglas Fir L	
18'	2x8s	2	3	3	4	2	4	2	3	4	18'											
	2x10s	2	2	2	3	2	3	2	2	3		2x12s	3	4	5	5	4	5	3	5	5	
	2x12s	2	2	2	2	2	2	2	2	2												
20'	2x8s	3	3	4	4	3	4	3	3	4	20'											
	2x10s	2	2	3	3	2	3	2	2	3		2x12s	4	5	5	6	4	6	4	5	6	
	2x12s	2	2	2	2	2	2	2	2	2												
22'	2x8s	3	4	4	4	3	4	3	4	4	22'											
	2x10s	2	3	3	3	2	3	2	3	3		2x12s	4	5	6	6	4	6	4	5	6	
	2x12s	2	2	2	2	2	2	2	2	2												
24'	2x8s	3	4	4	5	3	4	3	4	4	24'											
	2x10s	2	3	3	3	2	3	2	3	3		2x12s	4	6	6	7	5	7	4	6	7	
	2x12s	2	2	2	3	2	2	2	2	2												
26'	2x8s	3	4	4	5	3	5	3	4	5												
	2x10s	2	3	3	3	2	3	2	3	3												
	2x12s	2	2	2	3	2	3	2	2	3												
28'	2x8s	3	4	4	5	4	5	3	4	5												
	2x10s	2	3	3	4	3	3	2	3	4												
	2x12s	2	2	3	3	2	3	2	2	3												
30'	2x8s	4	5	5	5	4	5	3	5	5												
	2x10s	3	3	3	4	3	4	2	3	4												
	2x12s	2	2	3	3	2	3	2	3	3												
32'	2x8s	4	5	5	6	4	6	4	5	6												
	2x10s	3	3	4	4	3	4	3	3	4												
	2x12s	2	3	3	3	2	3	2	3	3												

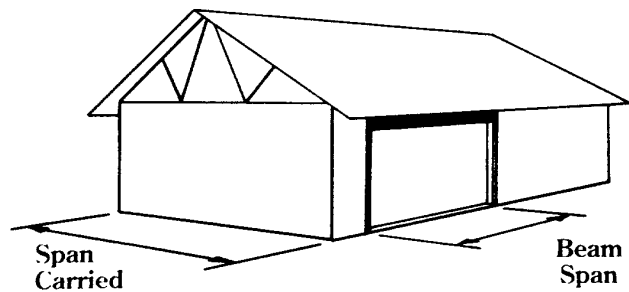

Design Criteria: Based on a 28 psf live load due to snow and a 12 psf dead load on a roof having a slope greater than 3:12. Roof loads include a 2' 0" overhang. Deflection is based on the span in inches divided by 240. Stresses in bending are adjusted for a snow load duration factor of 15 percent and a size adjustment factor per Table 23-I-A-1 of the 1994 Uniform Building Code. Minimum bearing length is 3 inches at each end.